

WESTPORT

ASSEMBLY INSTRUCTIONS

PLEASE USE WOOD GLUE & SCREWS ON ALL TENONS & HOLES

STEP 1

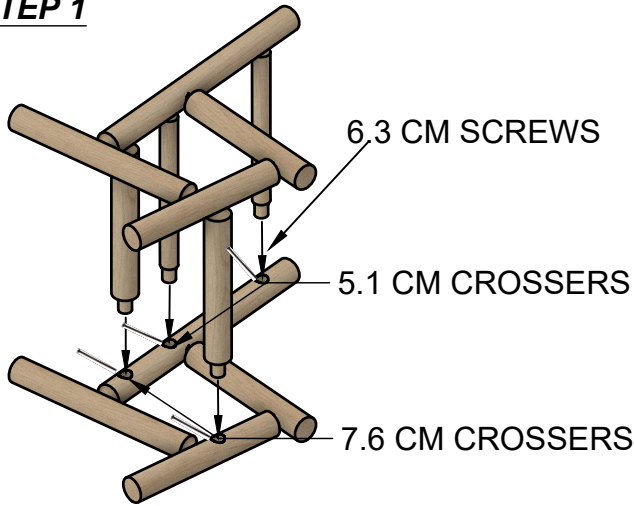

STEP 2

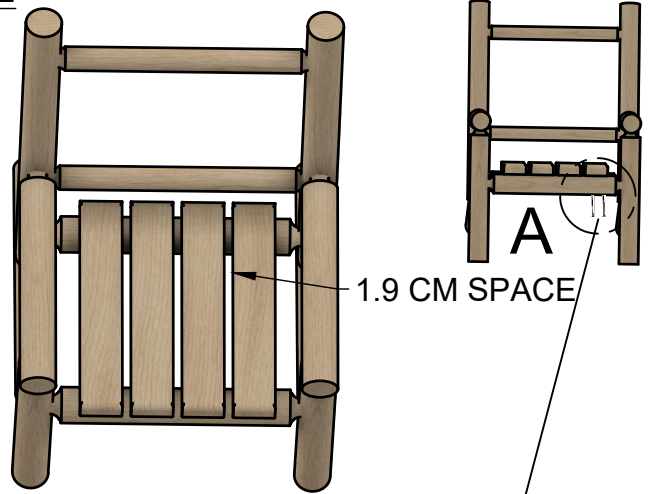

STEP 3

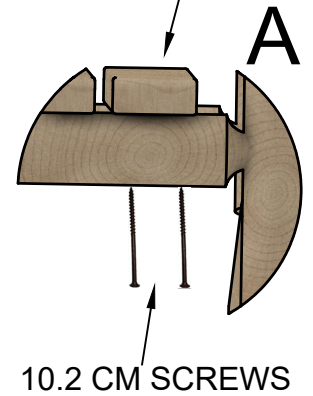
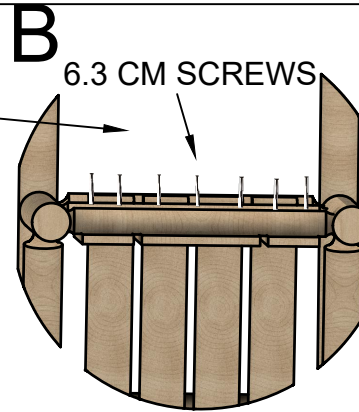
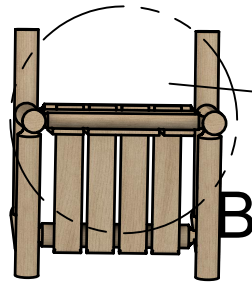
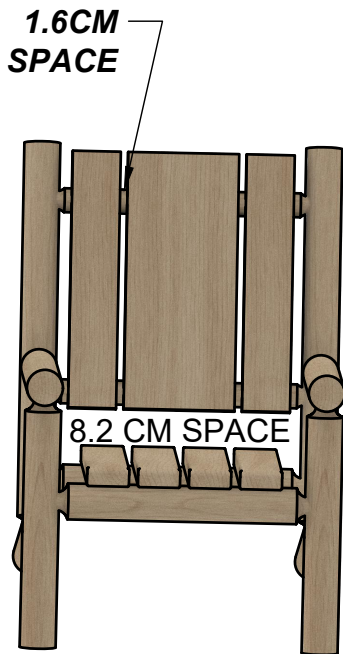

STEP 4

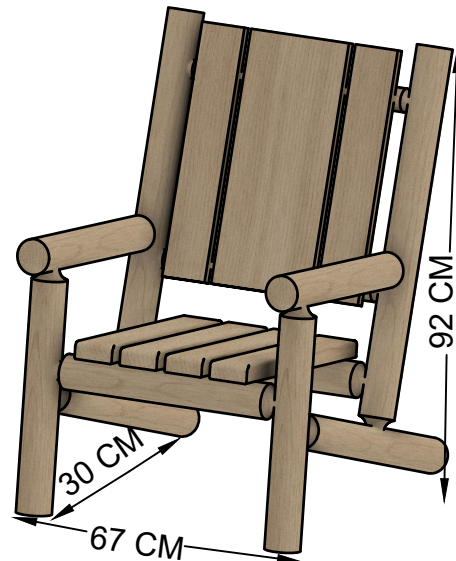

1 BOX CONTAINS:

CHAIR COMPONENTS:

- 2 - PRE-ASSEMBLED SIDES
- 2 - 7.6CM CROSSERS
- 2 - 5.1CM CROSSERS
- 4 - SEAT SLATS
- 3 - BACK BOARDS

HARDWARE:

- 23 SCREWS(6.3 CM)
- 16 SCREWS(10.2CM)
- 1 BOTTLE GLUE
- 1 #2 ROBERSON BIT

Please note that the result of checking is neither a split or a crack. In short it is an opening on the woods surface running parallel to the grain. It may be present in your cedar furniture and is a normal part of the process and can not be controlled by the manufactures or builder. It is perfectly normal and expected when purchasing cedar. Checking does not affect the structural integrity or performance of the wood itself since it does not pass through heartwood. Checking is not an indication of damaged furniture or goods and a varying amount of checking is to be expected